

LG-ITR2C-252117

DATA SHEET

SPEC.NO.: SZ19090501
DATE: 2019/09/09
REV. A/1

Approved By:

Checked By:

Prepared By:

■ Features

-
-
-
-
-
-

■ Descriptions

■ Applications

-
-
-
-
-

■ Device Selection Guide

Device No.	Chip Material	LENS COLOR

Package Dimensions

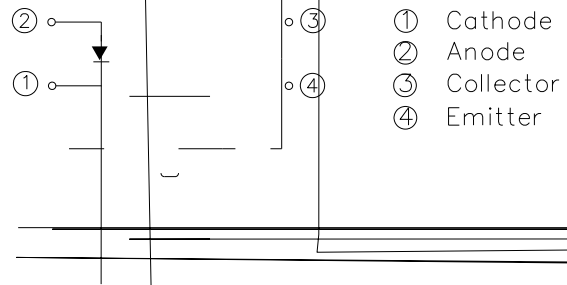
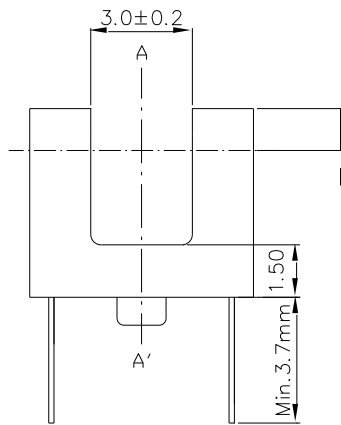
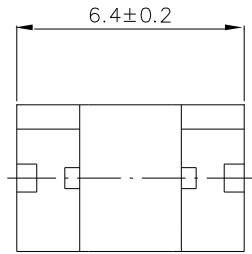

- ① Cathode
- ② Anode
- ③ Collector
- ④ Emitter

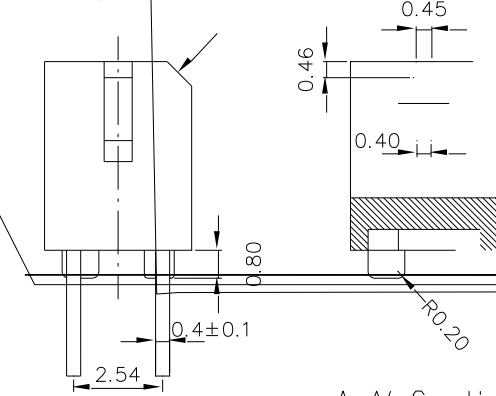

A-A' Section

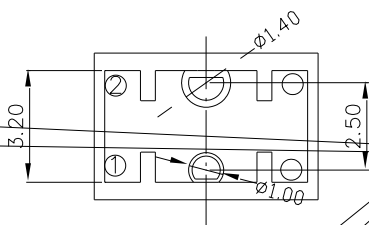

■ Absolute Maximum Ratings (Ta=25°C)

	°C			
	≤ μ			
				°C
				°C
				°C

* μ *

■ Electro-Optical Characteristics (Ta=25°C)

						μ
						μ
					μ	
		λ				
		θ				
					μ	
					μ	
						Ω

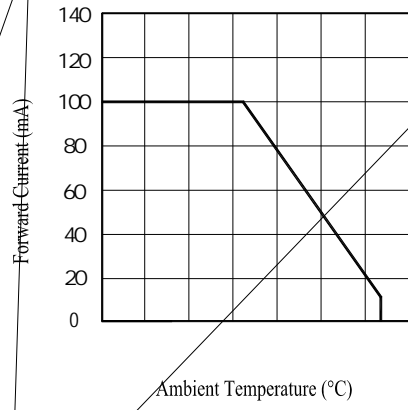

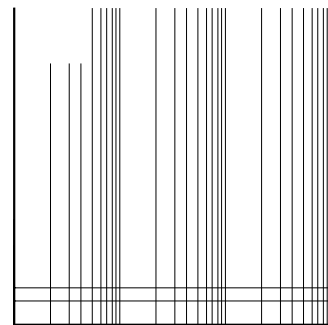
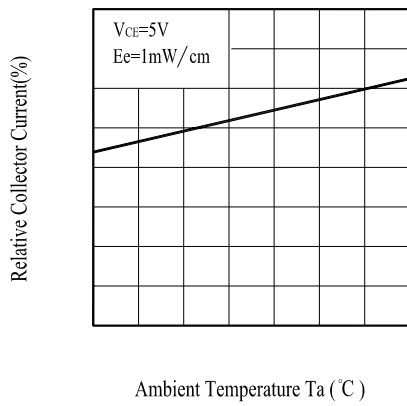
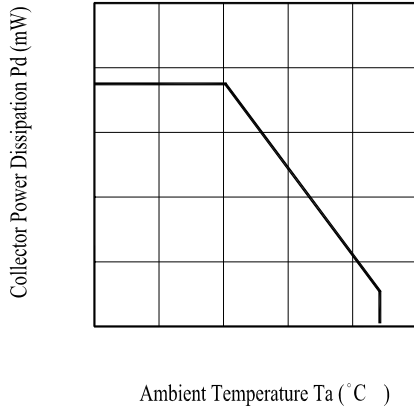

I_e