

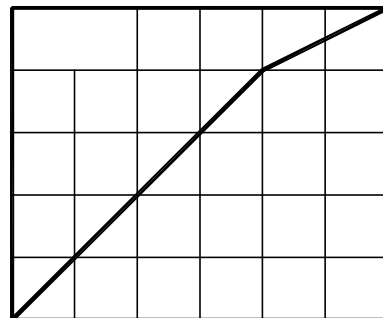

--	--	--	--

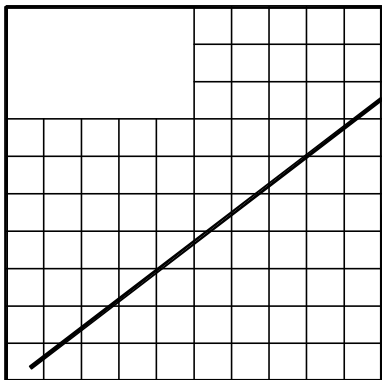

LIGHT

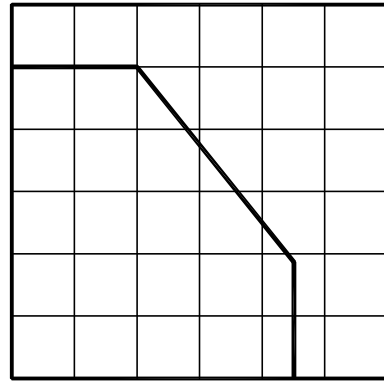
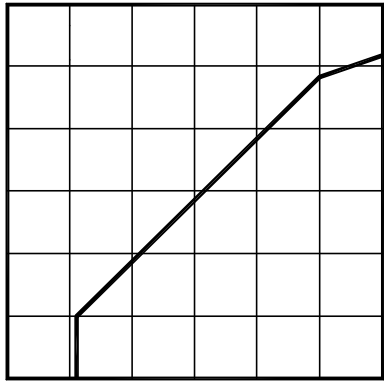

2

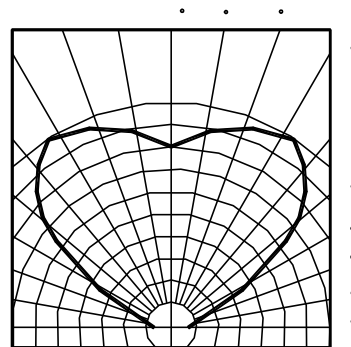
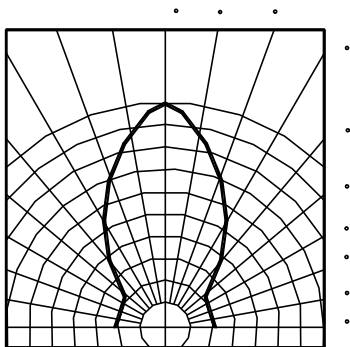

LIGHT

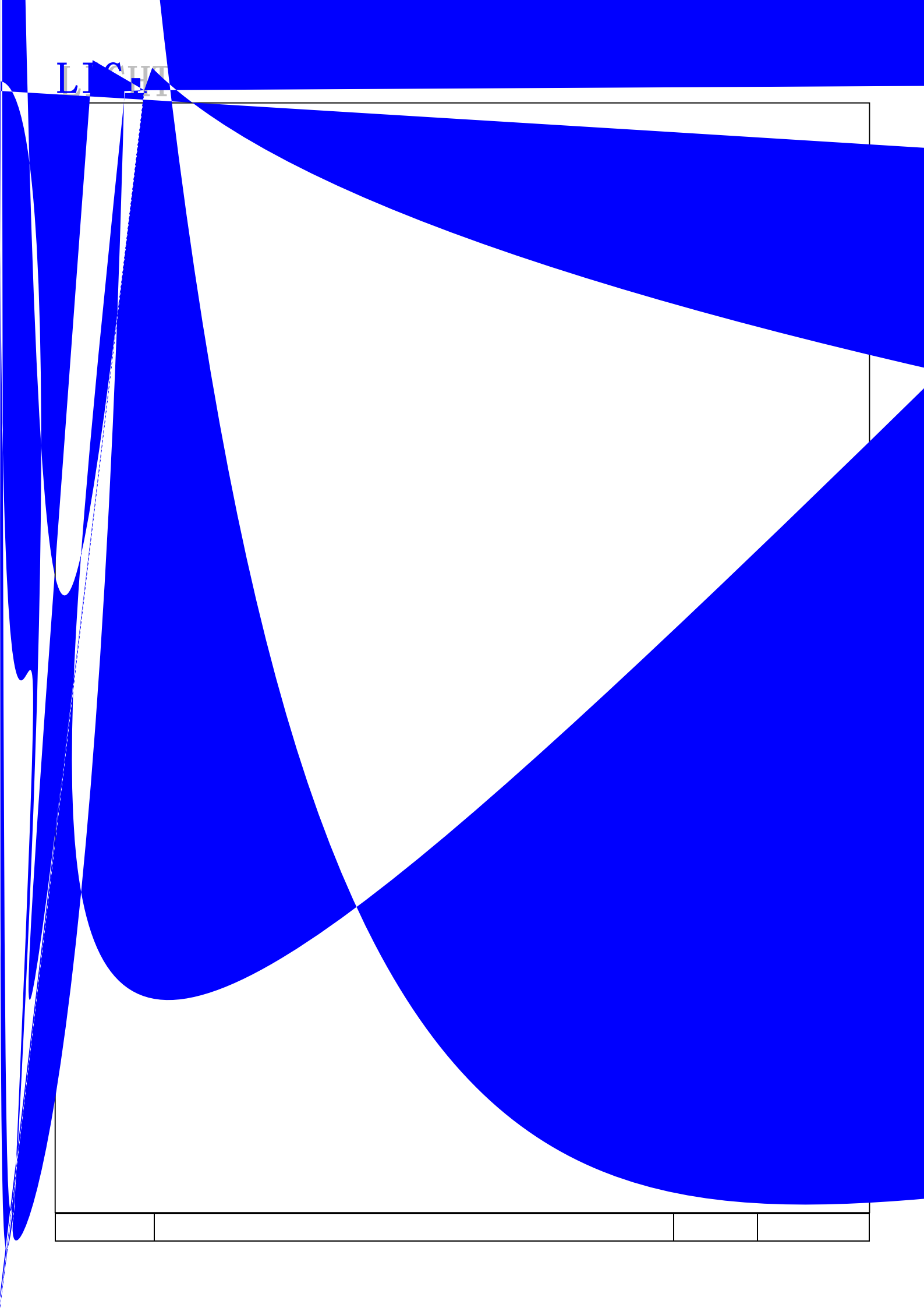

LIGHT 深圳莱特光电股份有限公司
 Light Electronics CO., LTD.

TYPE NO. : _____
 QUANTITY : _____
 BIN : _____
 DATE CODE : _____
 REMARKS : _____

LOT NO. : _____

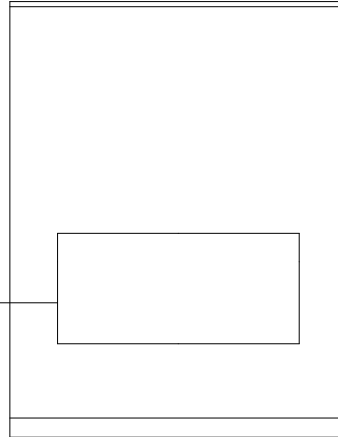

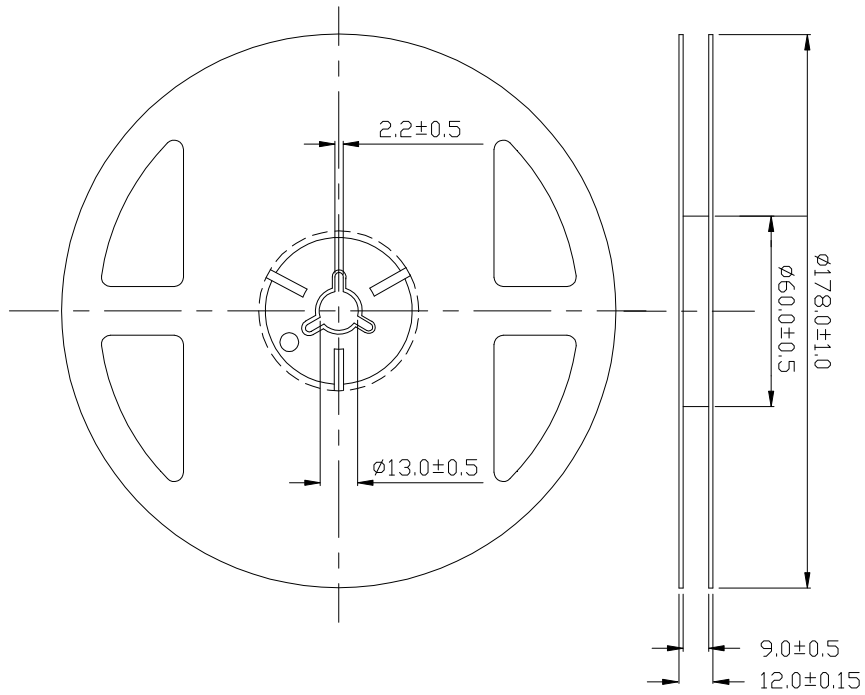
--	--	--	--

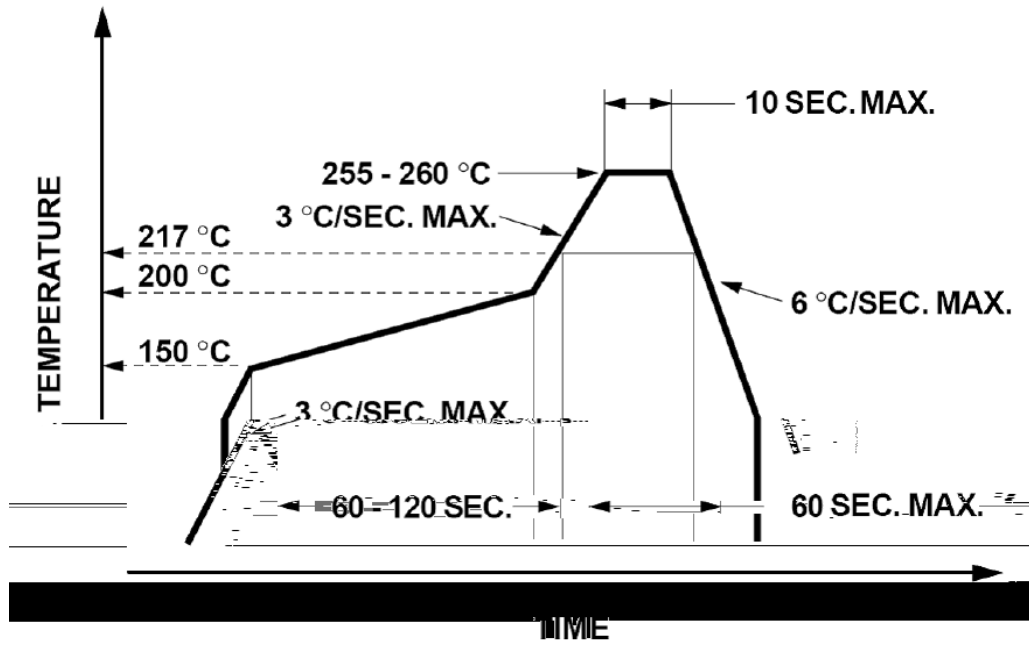

°C

